

A向
不按比例

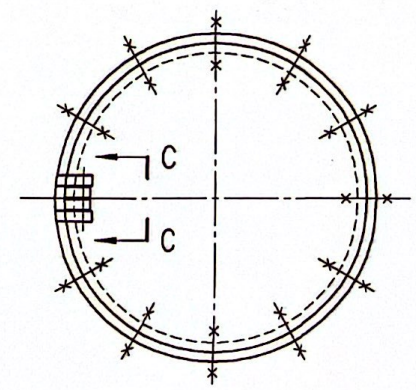

C-C
不按比例

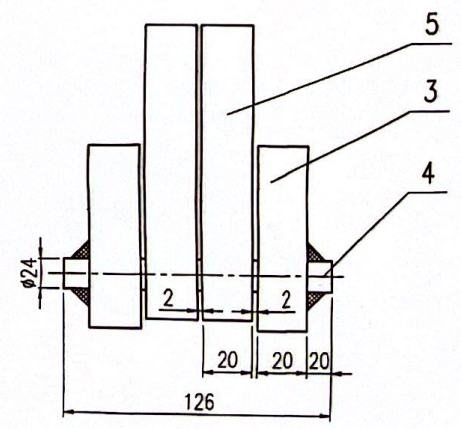

I
不按比例

II
不按比例

III
不按比例

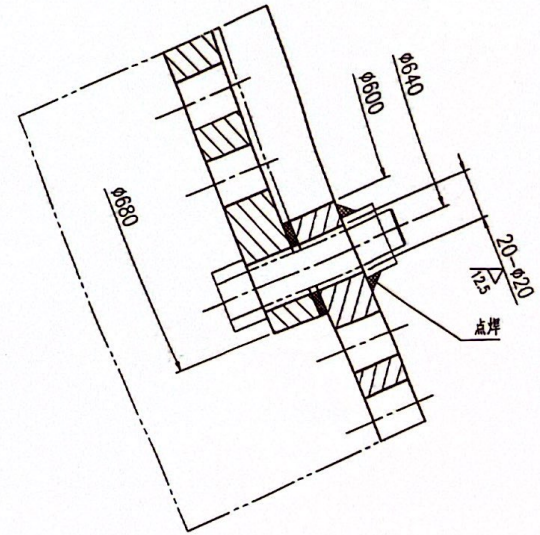
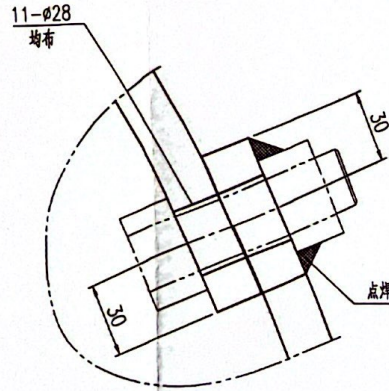
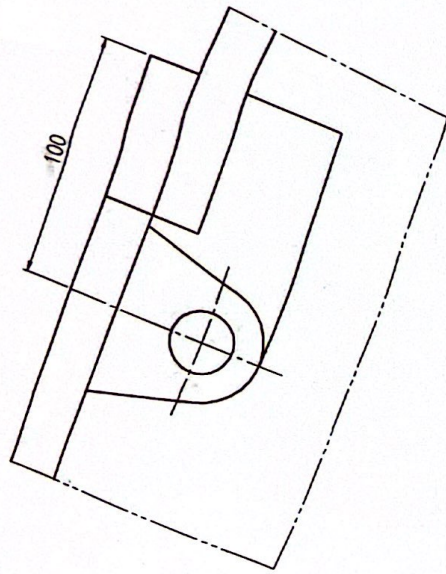

总重量: 4190 kg

件4详图
不按比例

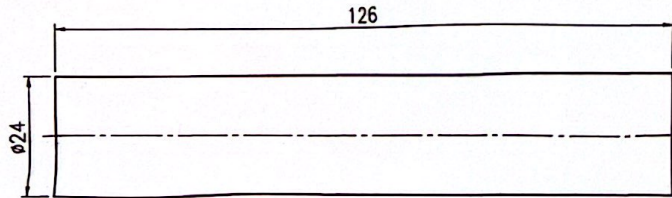

技术要求:

1. 焊接采用电焊, 焊条型号按焊接规程,
2. 人孔盖开孔大小及排列同孔板.
3. 按零件交货, 交货前, 应试组装.

件号 PART NO.	图号或标准号 DRAWING NO. OR	名称 DESCRIPTION	数量 QTY.	材料 MATERIAL	SINGLE 重量(kg)	TOTAL 重量(kg)	备注 REMARK
6	SCR-21-1	球冠 SR300 t=20	2	15CrMoR	66	132	
5	SCR-21-2	R15501 连接件II t=20	4	15CrMoR	0.76	3.04	
4	按本图	R15501 轴 φ24 L=126	4	0Cr18Ni9	0.3	1.2	
3	SCR-21-2	R15501连接件I t=20	4	15CrMoR	0.38	1.52	
2	SCR-21-1	孔板 t=20	4	15CrMoR	956	3824	
1	SCR-21-1	人孔盖 φ680 t=20	4	15CrMoR	57	228	

江苏索普赛瑞装备制造有限公司

施工用图

产品工程部

版次	修改内容	修改	校对	审核

本图及相关文件版权属于江苏索普赛瑞装备制造有限公司所有, 任何单位和个人未经江苏索普赛瑞装备制造有限公司书面许可, 不得以任何方式复制或扩散至第三方, 违者应承担法律责任。 THIS DRAWING AND RELEVANT DOCUMENTS' COPYRIGHT BELONGS TO SOPO CERRE EQUIPMENT MANUFACTURING CO., LTD. THEY MAY NOT BE REPRODUCED OR DISCLOSED TO ANY THIRD PARTY IN ANY FORM WITHOUT THE PRIOR WRITTEN PERMISSION OF SOPO CERRE EQUIPMENT MANUFACTURING CO., LTD. THE OFFENDERS SHALL BEAR THE CORRESPONDING LEGAL RESPONSIBILITY.

江苏索普赛瑞装备制造有限公司 JIANGSU SOPO-CERRE EQUIPMENT MANUFACTURING CO., LTD.			项目名称 ENTRY NAME		
设计 DESIGN	张地东	2024.4.24	甲醇合成塔内部支撑件 装配图		
校对 CHECK	张杰	2024.4.24			
标准化审查 S.T.D	宋书强	2024.4.24			
审核 REVIEW	张见远	2024.4.24			
			设计阶段 DESIGN PHASE		
			比例 SCALE 1: 10 版本 REV.		
			第 1 张 SHEET 共 1 张 TOT.		
			图号 DWG NO. SCR-21-0		



CS 扫描全能王

3亿人都在用的扫描App

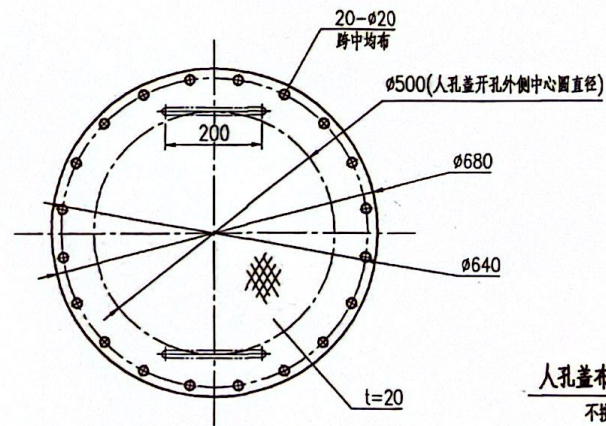
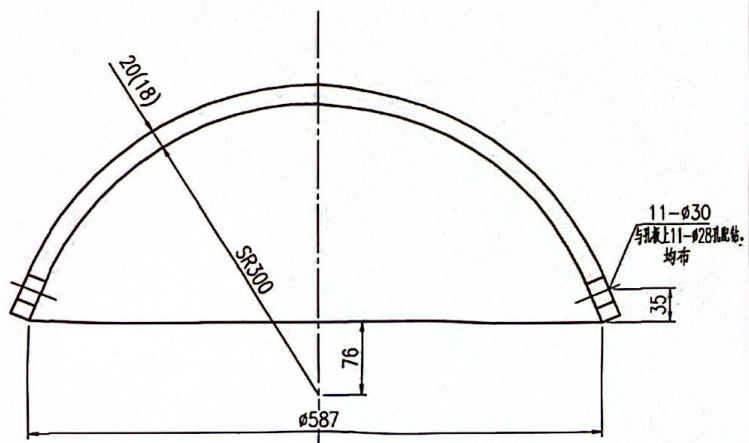

人孔盖布孔示意图
不按比例

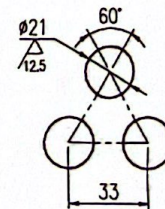

25
知迪 ✓
其余 ✓

6	球冠 SR300 t=20	15CrMoR	66	/	SCR-21-1	SCR-21-0
件号 PART NO.	名称 DESCRIPTION	材料 MATERIAL	重量(kg) WEIGHT	比例 SCALE	所在图号 DRAWING NO.	装配图号 ASS. DWG. NO.

1	人孔盖 $\phi 680$ t=20	15CrMoR	57	/	SCR-21-1	SCR-21-0
件号 PART NO.	名称 DESCRIPTION	材料 MATERIAL	重量(kg) WEIGHT	比例 SCALE	所在图号 DRAWING NO.	装配图号 ASS. DWG. NO.



CS 扫描全能王

3亿人都在用的扫描App

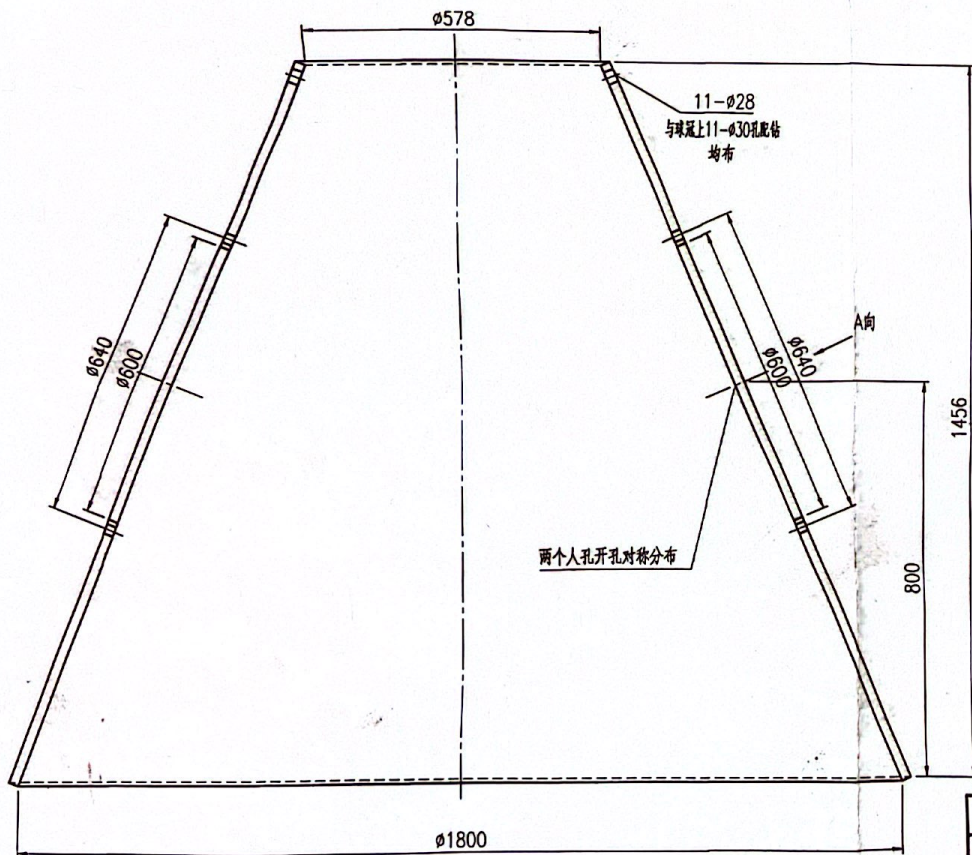

孔板布孔示意图

不按比例

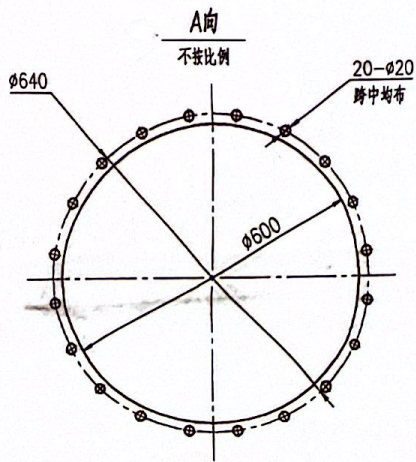
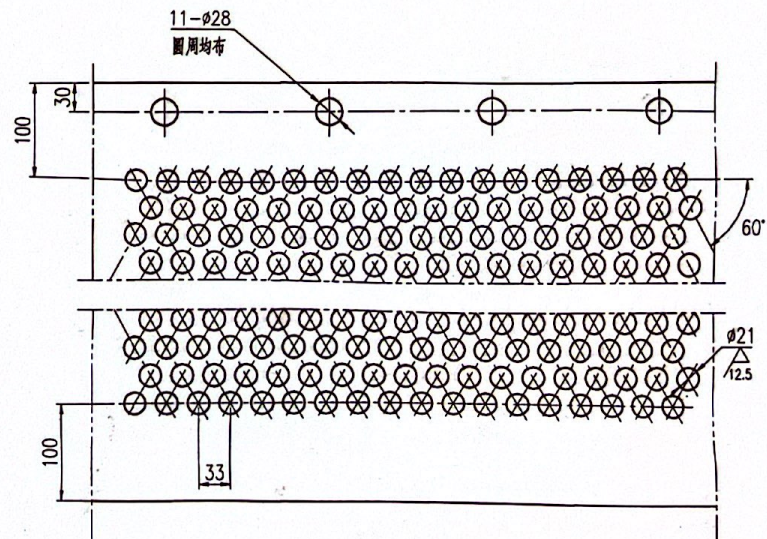

孔板布孔示意图

不按比例

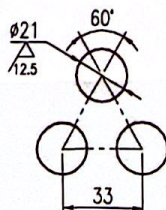

2	孔板 t=20	15CrMoR	956	/	SCR-21-1	SCR-21-0
件号 PART NO.	名称 DESCRIPTION	材料 MATERIAL	重量(kg) WEIGHT	比例 SCALE	所在图号 DRAWING NO.	装配图号 ASS. DWG. NO.
受控文件						
版次	修改内容	日期	修改	校对	审核	
<p>本图纸及相关文件版权属于江苏索普赛瑞装备制造有限公司所有,任何单位和个人未经江苏索普赛瑞装备制造有限公司书面许可,不得以任何方式复制或扩散至第三方,违者应承担法律责任。 THIS DRAWING AND RELEVANT DOCUMENTS' COPYRIGHT BELONGS TO SOPO CERE EQUIPMENT MANUFACTURING CO., LTD. THEY MAY NOT BE REPRODUCED OR DISCLOSED TO ANY THIRD PARTY IN ANY FORM WITHOUT THE PRIOR WRITTEN PERMISSION OF SOPO CERE EQUIPMENT MANUFACTURING CO., LTD. THE OFFENDERS SHALL BEAR THE CORRESPONDING LEGAL RESPONSIBILITY.</p>						
 江苏索普赛瑞装备制造有限公司 JIANGSU SOPO-CERE EQUIPMENT MANUFACTURING CO., LTD.					项目名称 ENTRY NAME	
设计 DESIGN	褚旭东	2024.4.24	甲醇合成塔内部支撑件 零件图		设计阶段 DESIGN PHASE	
校对 CHECK	蔡杰	2024.4.24			比例 SCALE 1:10	版本 REV.
标准化审查 S.T.D	宋志强	2024.4.24			第 1 张 SHEET 共 1 张 TOT.	
审核 REVIEW	徐恩五	2024.4.24			图号	SCR-21-1
批准 RATIFY					DWG NO.	

